

**STR. FEMALE MODULE 6 CRIMP TYPE INSERTS**  
**COAX FOR 2.6/50 CABLE**

**R694.252.537**

Series : MCC2

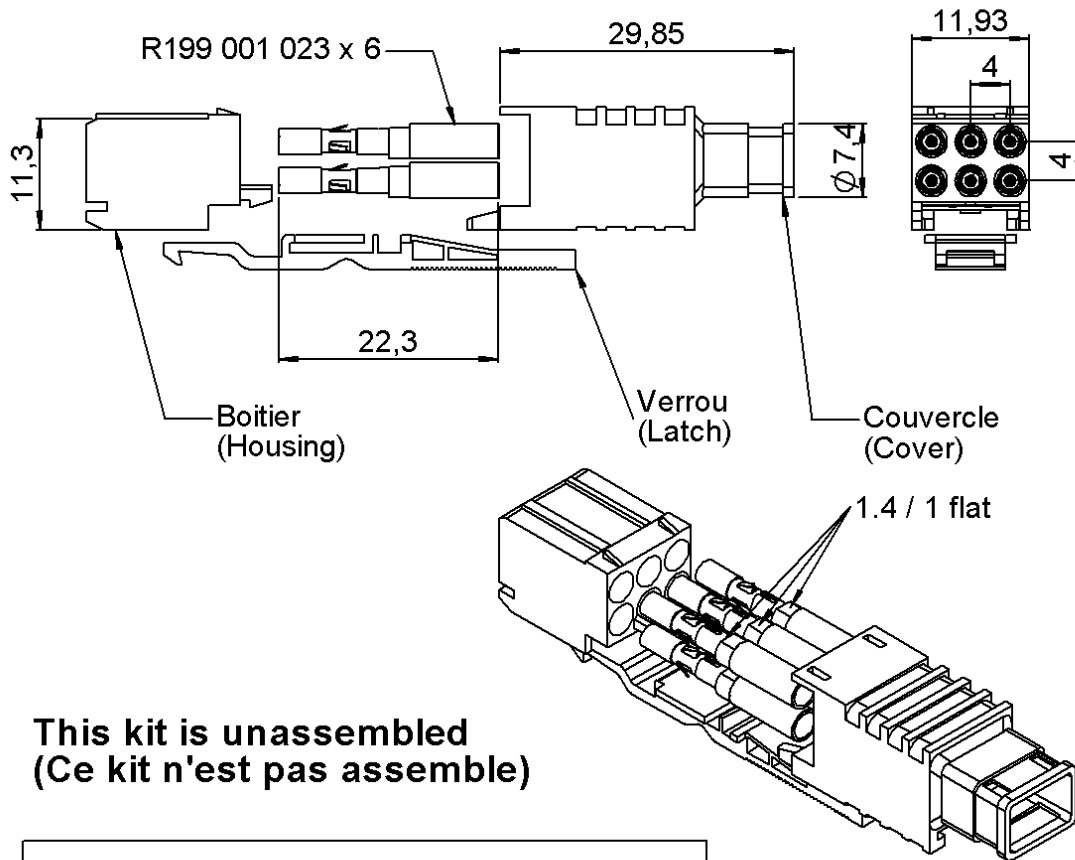

**This kit is unassembled  
 (Ce kit n'est pas assemble)**

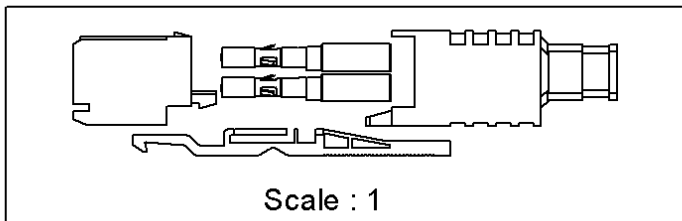

All dimensions are in mm.



COMPONENTS	MATERIALS	PLATING (µm)
BODY	BRASS	NPGR
CENTER CONTACT	BERYLLIUM COPPER	NPGR
OUTER CONTACT	-	-
INSULATOR	PTFE+PEEK	-
GASKET	-	-
OTHERS PARTS	LIQUID CRISTAL POLYMER	-
.	-	-
.	-	-

Issue : 0746 F

In the effort to improve our products, we reserve the right to make changes judged to be necessary.



**STR. FEMALE MODULE 6 CRIMP TYPE INSERTS**

**R694.252.537**

**COAX FOR 2.6/50 CABLE**

Series : **MCC2**

**PACKAGING**

Standard	Unit	Other
<b>100</b>	-	<b>Contact us</b>

**SPECIFICATION**

**ELECTRICAL CHARACTERISTICS**

Impedance		<b>50</b> Ω
Frequency		<b>0-6</b> GHz
VSWR	<b>1.3*</b> +	<b>0,0000</b> x F(GHz) Maxi
Insertion loss		<b>0.2</b> √F(GHz) dB Maxi
RF leakage	- (	- F(GHz)) dB Maxi
Voltage rating		<b>500</b> Veff Maxi
Dielectric withstanding voltage		<b>750</b> Veff mini
Insulation resistance		<b>5000</b> MΩ mini

**CABLE ASSEMBLY**

Stripping	a	b	c	d	e	f
mm	2,50	5,00	10,5	0,00	8,00	0,00

Assembly instruction : **Crimp 02**

Recommended cable(s)

RG 316  
KX 22A  
RG 188

Characteristics indicated on this data sheet are those that can be achieved with the highest performance cable. Intrinsic limitations of the cable may diminish the performance of the assembly

Cable retention

- pull off **53** N mini  
- torque **NA** N.cm

**MECHANICAL CHARACTERISTICS**

Center contact retention		
Axial force – Mating end	<b>NA</b>	N mini
Axial force – Opposite end	<b>NA</b>	N mini
Torque	<b>NA</b>	N.cm mini

**TOOLING**

Part Number	Description	Hexagon
.	.	.
R282.211.000	CRIMPING TOOL	3.25
. Or spare tools	-	
R282.293.000	CRIMPING TOOL M22520/5-01	
R282.235.003	CRIMPING DIES	3.25
. And - (et)		
R282.281.000	CRIMPING TOOL	2X4 pos 4
R282.967.030	POSITIONER FOR TOOL R282 281 000	

Recommended torque		
Mating	<b>NA</b>	N.cm
Panel nut	<b>NA</b>	N.cm
Clamp nut	<b>NA</b>	N.cm
A/F clamp nut	<b>0,0000</b>	mm

Mating life	<b>500</b>	Cycles mini
Weight	<b>7,4800</b>	g

**ENVIRONMENTAL**

Operating temperature	<b>-25/+125</b>	° C
Hermetic seal	<b>NA</b>	Atm.cm3/s
Panel leakage	<b>NA</b>	

**OTHER CHARACTERISTICS**

\* 0 to 3 GHz

Issue : **0746 F**

In the effort to improve our products, we reserve the right to make changes judged to be necessary.



**STR. FEMALE MODULE 6 CRIMP TYPE INSERTS**  
**COAX FOR 2.6/50 CABLE**

**R694.252.537**

Series : MCC2

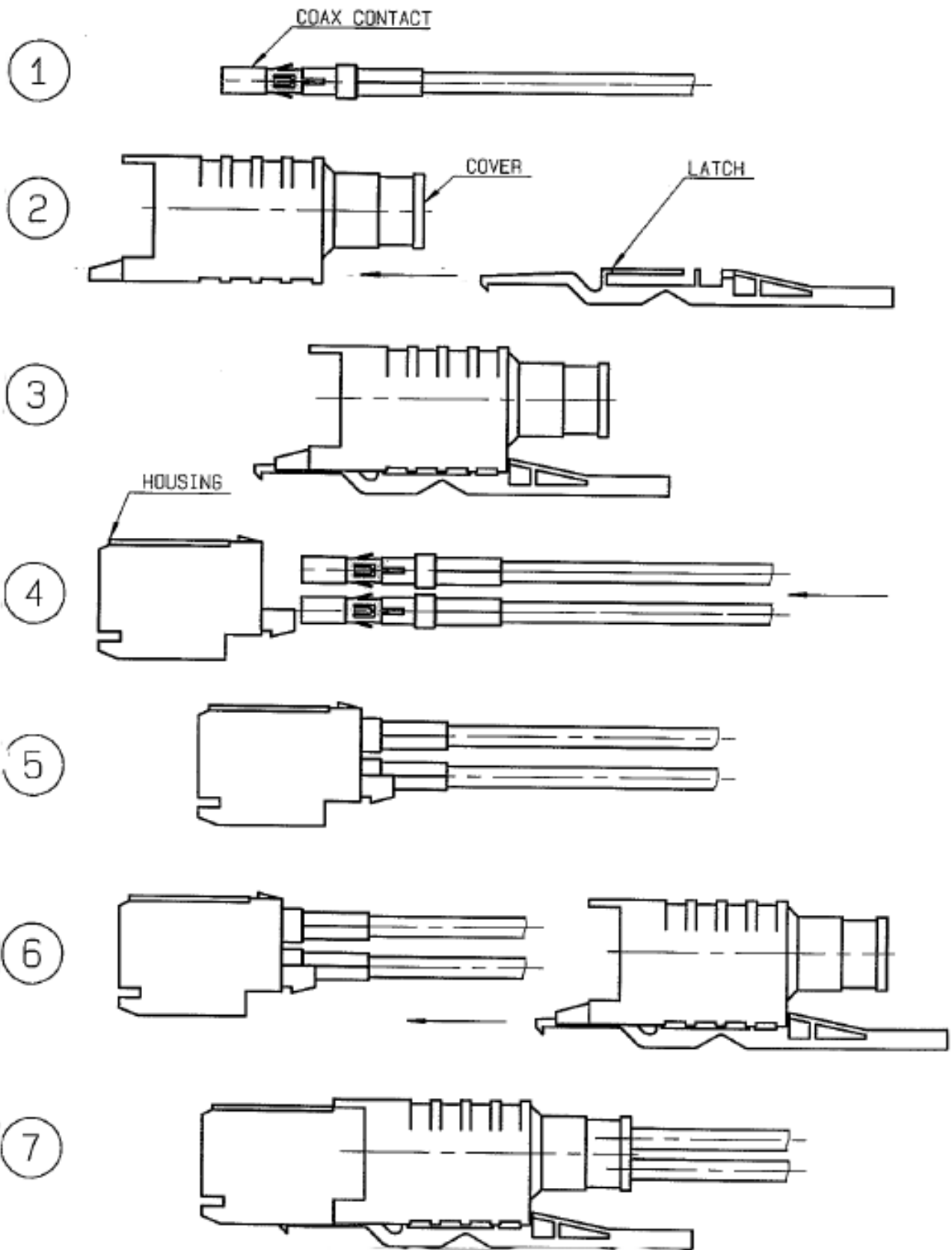

Issue : 0746 F

In the effort to improve our products, we reserve the right to make changes judged to be necessary.

